



- IEC 62053-22 Class 0.2S* /0.5S
- ANSI C12.1 Class 0.2
- True RMS @ 128 Samples/Cycle*
- THD with 63rd* Ind. Harmonics
- K-Factor, Crest Factor and TDD
- Unbalance & Phase Angle
- Demands and Max. Demands
- Max./Min. Logs with Timestamp
- 16MB* Non-volatile Log Memory
- Freeze Logs and SOE Logs
- 5xDR Logs @ 16 parameters each
- Multi-Tariff TOU and 9 Setpoints
- Large, Backlit Dot-Matrix LCD
- 1-Cycle Real-Time WF Display
- Opt. SCCT & Rogowski Coil* Inputs
- 1xEthernet & 1xRS-485
- Modbus RTU, BACnet MS/TP, DNP 3.0
- Modbus TCP, HTTP, SMTP, SNTP, TFTP
- 4xDI, 2xDO
- Opt. 1xI4+1xI1r+1xAI, 2xAO, 3xRTD
- IP65 Enclosure with No Openings
- Standard Tropicalization
- Industrial Grade Components
- Ext. Operating Temp. & Warranty

*The PMC-53A-E with Firmware V2.00.01 and later versions support the selection of Class 0.2S accuracy model and Rogowski coil inputs, and feature enhanced capabilities. These enhancements include an expansion from 31st to 63rd individual harmonics, True RMS sampling rate increased from 64 to 128 Samples/Cycle, an addition of Voltage and Frequency Deviations monitoring, and an extended log memory of 16MB (double the previous 8MB capacity).

Designed For Reliability

Manufactured To Last



Ethernet Multifunction Meter



The PMC-53A-E Ethernet Multifunction Meter is CET's latest offer for the digital power/energy metering market. Housed in a standard DIN form factor measuring 96x96x83.6mm, it is perfectly suited for industrial, commercial and utility applications requiring direct Ethernet connectivity. The PMC-53A-E features quality construction, multifunction measurements and a large, backlit, Dot-Matrix LCD that is easy to navigate and user friendly. Compliance with the IEC 62053-22 Class 0.2S*/0.5S and ANSI C12.1 Class 0.2, it is a cost-effective replacement for analog instrumentation and is capable of displaying 4 measurements at once. It also optionally provides an I4 input for Neutral Current Measurement, one 0/4-20mA Analog Input for measuring external transducer signals, an Ir Input for Residual Current Measurement, or two Analog Outputs for real-time monitoring, or three RTDs (PT100 sensors not included) for temperature measurement. With a standard 10Base-T/100Base-TX Ethernet Port and an RS-485 port supporting multiple protocols, the PMC-53A-E can be easily integrated into Energy Management Systems as well as Building and Utility Automation Systems.

Typical Applications

- Industrial, Commercial and Utility Substation Metering
- Building, Factory and Process Automation
- Sub-metering and Cost Allocation
- Retrofit applications with Split-Core Current Transformers and Rogowski Coils*

Features Summary

Basic Measurements

- ULN, ULL per phase and Average with Neutral-to-Ground Voltage (Ung)
- Current per phase and Average with calculated Neutral
- P, Q, S, PF per phase and Total
- kWh, kvarh Imp./Exp./Net/Total and kVAh Total
- Frequency
- Device Operating Time (Running Hours)
- Optional Neutral Current (I4) and Residual Current (Ir) Measurement

Advanced Measurements

- 1-cycle Real-time U & I Waveform Display @ 1s update
- U and I THD, TOHD, TEHD and Harmonics analysis up to 63rd
- Current TDD, TDD Odd, TDD Even, K-Factor and Crest Factor
- U and I Phase Angle
- Displacement PF
- Fundamental U, I and P per phase
- Total Fundamental P & Total Harmonic P
- U and I Unbalance and Sequence
- ULN, ULL Over/Under Deviation and Frequency Deviation*
- %kvarh Imp./kWh Imp., %kvarh Exp./kWh Imp. for Last Day & Last 30 Days
- Interval Energy for kWh/kvarh Imp./Exp. and kVAh
- Present, Predicted and Max. Demands for ULN, ULL, I per phase and Average as well as P/Q/S Total with Timestamp for This Month & Last Month (or Since Last Reset & Before Last Reset)
- Two TOU schedules, each providing
 - 12 Seasons*
 - 20 Daily Profiles, each with 12 Periods*
 - 90 Holidays or Alternate Days
 - 8 Tariffs, each providing the following information
 - Total and 3-phase kWh/kvarh Imp./Exp., kVAh
 - P/Q/S Max. Demands
- 12 Monthly Logs of kWh, kvarh Imp./Exp./Net/Total, kVAh and kvarh Q1-Q4 as well as kWh/kvarh Imp./Exp. and kVAh per Tariff

Ease of use

- Large, backlit, Dot-Matrix LCD display with wide viewing angle
- Intuitive user interface
- LED indicators for Energy Pulsing and Communication activities
- Password protected setup via Front Panel, Web Server or free software
- Easy installation with mounting clips, no tools required

Setpoints

- 9 user programmable setpoints with extensive monitoring parameters including Voltage, Current, Power, PF, Current and Power Demand, Unbalance and THD, etc.
- Configurable thresholds, time delays, DO and Alarm Email triggers

Carbon Emission Metering ^

- Carbon Emission measurements for This Month & This Year & Total Cumulative
- Configurable Carbon Emission Factor and Associated kWh Imp./Exp. for both Transmission & Distribution Lines & Load-side Power Generation Equipment
- Storage of up to 12 monthly & 12 annual historical Carbon Emission logs

SOE Logs

- 100 events time-stamped to ± 1 ms resolution
- Setup changes, Setpoint, DI status changes and DO operations

Max./Min. Log

- Max./Min. Log with Timestamp for Real-time measurements such as Voltage, Current, In, I4, Ir, Frequency, P, Q, S, PF, Unbalance, K-Factor, Crest Factor and THD
- Configurable for This Month & Last Month (or Since Last Reset & Before Last Reset)

Freeze Logs

- 60 Daily Freeze Logs for kWh/kvarh/kVAh Total and P/Q/S Max. Demands
- 36 Monthly Freeze Logs for kWh/kvarh/kVAh Total and P/Q/S Max. Demands with Timestamp

Data Recorder (DR)

- 5 Data Recorders of 16 parameters* each for Real-time measurements, Harmonics, Energy, Demand, TOU, Pulse Counters, etc.
- Recording interval from 1 minute to 40 days
- Configurable capacity up to a max. of 1250* days (> 3 years) at 15-minute interval for 1 Data Recorder with 16 parameters for **HK BEC 2021**

Compliant Recording

Diagnostics

- Frequency Out-of-Range, Loss of Voltage / Current
- P Direction per phase and Total, Possible incorrect CT Polarity
- Incorrect U & I Phase Sequence
- Disconnection of Residual Current Input

Communications

- 1x10Base-T/100Base-TX Ethernet Port with RJ45 connector
- 1xOptically isolated RS-485 port with baud rate from 1.2kbps to 38.4kbps
- Built-in Web Server for easy data viewing and setup configurations
- Protocol supported: Modbus TCP/RTU, BACnet MS/TP, DNP 3.0, HTTP, SMTP, SNMP, TFTP and Ethernet Gateway

Real-Time Clock

- Battery-backed Real-time Clock with 6ppm accuracy (<0.5s per day)

System Integration

- Supported by CET's PecStar® iEMS
- Easy integration into Building Automation Systems with BACnet MS/TP or Modbus RTU and Utility Substation Automation with DNP 3.0
- The on-board password protected Web Server allows complete access to its data and supports the configuration for most of the Setup parameters via a standard web browser

Inputs and Outputs

Digital Inputs

- 4 channels, volt free dry contact, 24VDC internally wetted
- 1000Hz sampling for status monitoring with programmable debounce
- Pulse counting with programmable weight for each channel for collecting WAGES (Water, Air, Gas, Electricity, Steam) information
- Tariff switching based on DI status

*These features are upgraded in PMC-53A-E with Firmware V2.00.01 or later.

^The Carbon Emission Metering is available in Firmware V2.00.03 or later.



Digital Outputs

- 2 Form A Mechanical Relays for alarming and general purpose control

Pulse Outputs (Optional)

- 2 Form A Solid State Relays for kWh and kvarh pulsing

Expansion Module Options

- I4 Current Input + AI (0/4-20mA) + Ir Input (0-0.5mA)
- 2xAO (0/4-20mA)~
- 3xRTD (PT100 sensors not included)~

~The option is available in Firmware V2.00.03 or later.

Technical Specifications

Voltage Inputs (V1, V2, V3, VN)	
Standard Un Range	400VLN/690VLL
Overload	10V to 2xUn
Burden	2xUn continuous, 5xUn for 1s
Measurement Category	<0.02VA per phase
Frequency	CAT III 600V
Frequency	45-65Hz
Current Inputs (-I11, I12, -I21, I22, -I31, I32, Optional -I41, I42)	
Standard Range	5A (Optional 1A)
Starting Current	0.1% to 200% In
Overload	0.1% In
Burden	2xIn continuous, 20xIn for 1s
SCCT Options	<0.15VA per phase @ 5A
Rogowski Coil Options	100A/200A/400A/800A/1600A to 40mA
400A/1200A/2500A/5000A to 40mA	
Power Supply (L/+, N/-)	
Standard	60-250VAC, ±10%, 47-440Hz
Burden	24-250VDC, ±10%
Overvoltage Category	<4W
	OVC III up to 300VLN
Digital Inputs (DI1, DI2, DI3, DI4, DIC)	
Type	Dry contact, 24VDC internally wetted
Sampling	1000Hz
Hysteresis	1ms minimum
Digital Outputs (DO11, DO12, DO21, DO22)	
Type	Form A Mechanical Relay
Loading	5A @ 250VAC or 30VDC
Load Type	Resistive
Optional SS Pulse Outputs (E1+, E1-, E2+, E2-)	
Type	Form A Solid State Relay
Isolation	Optical
Load Type	Resistive
Output	Optocoupler output as ON-OFF
Max. Load Voltage	50VDC
Max. Forward Current	50mA
Optional Residual Current Input (-IR, IR)	
In Range	0.5mA
CT Type	2% to 200% In
	Solid-Core or Split-Core Residual CT
Optional Analog Input (AI+, AI-)	
Type	0-20 / 4-20 mA DC
Overload	24mA DC maximum
Optional Analog Outputs (AO1+, AO1-, AO2+, AO2-)	
Type	0-20 / 4-20 mA DC
Loading	500Ω maximum
Overload	24mA DC maximum
Optional RTD Inputs (TC11, TC12, TC21, TC22, TC31, TC32)	
Type	Platinum Resistor PT100 (Sensor Not Included)
Range	-50°C to 200°C
Cable Length	3000mm
Protective Tube Length	30mm
Tightening Installation Torque	
Current Inputs	7.1 kgf.cm / M3.5 / 6.28 lb-in / 0.7 N.m
Power Supply, Voltage Inputs, RS-485 and I/O	4 kgf.cm / M3 / 3.54 lb-in / 0.4 N.m
Environmental Conditions	
Operating Temp.	-25°C to 70°C
Storage Temp.	-40°C to 85°C
Humidity	5% to 95% non-condensing
Atmospheric Pressure	70 kPa to 106 kPa
Altitude	< 2000m
Pollution Degree	2
Location / Mounting	For indoor use only
Mechanical Characteristics	
Panel Cutout	92x92 mm (3.62"x3.62")
Unit Dimensions	96x96x83.6 mm
IP Rating	IP65 (Front Panel), IP30 (Body)

Accessories

1A/0.5mA Residual Current Sensor

- CT517203** Phase Current Range: 0-160A Aperture=Ø46mm, Accuracy: Class 0.5
- CT517403** Phase Current Range: 0-400A Aperture=Ø80mm, Accuracy: Class 0.5
- CT519703** Phase Current Range: 0-630A Aperture=220x50mm, Accuracy: Class 0.5
- CT517603** Phase Current Range: 0-1000A Aperture=Ø120mm, Accuracy: Class 0.5



Solid-Core Current Sensor

- CT553203** Phase Current Range: 0-160A Aperture=Ø48mm, Accuracy: Class 3
- CT553303** Phase Current Range: 0-225A Aperture=Ø68mm, Accuracy: Class 3



Split-Core Current Sensor

Split-Core CT

- PMC-SCCT-100A-40mA-16-A**, L=2m, Aperture= Ø16mm 1-phase 100A/40mA split-core CT, Accuracy: Class 0.5
- PMC-SCCT-200A-40mA-24-A**, L=2m, Aperture= Ø24mm 1-phase 200A/40mA split-core CT, Accuracy: Class 0.5
- PMC-SCCT-400A-40mA-35-A**, L=2m, Aperture= Ø35mm 1-phase 400A/40mA split-core CT, Accuracy: Class 0.5
- PMC-SCCT-800A-40mA-A**, L=2m, Aperture= 80x50mm 1-phase 800A/40mA split-core CT, Accuracy: Class 0.5
- PMC-SCCT-1600A-40mA-A**, L=2m, Aperture= 130x55mm 1-phase 1600A/40mA split-core CT, Accuracy: Class 0.5



Rogowski Coil

3-phase Rogowski Coil



- Optional Extension Cable**
SP13-F-M-5 (5m)
SP13-F-M-10 (10m)

- Adapter Cable**
SP-13-53AE (0.25m)

- 10-25VDC Power Supply**

- PMC-RC-400A-40mA-3P-100-PY-W-P**
3-phase 400A/40mA Rogowski Coil, aperture=Ø100mm

- PMC-RC-1200A-40mA-3P-150-PY-W-P**
3-phase 1200A/40mA Rogowski Coil, aperture=Ø150mm

- PMC-RC-2500A-40mA-3P-200-PY-W-P**
3-phase 2500A/40mA Rogowski Coil, aperture=Ø200mm

- PMC-RC-5000A-40mA-3P-300-PY-W-P**
3-phase 5000A/40mA Rogowski Coil, aperture=Ø300mm

1-phase Rogowski Coil



- Optional Extension Cable**
SP13-4-F-M-5 (5m)
SP13-4-F-M-10 (10m)

- Adapter Cable**
SP-13-53AE-I4 (0.25m)

- 10-25VDC Power Supply**

- PMC-RC-400A-40mA-1P-100-PY-W-P**
1-phase 400A/40mA Rogowski Coil, aperture=Ø100mm

- PMC-RC-1200A-40mA-1P-150-PY-W-P**
1-phase 1200A/40mA Rogowski Coil, aperture=Ø150mm

- PMC-RC-2500A-40mA-1P-200-PY-W-P**
1-phase 2500A/40mA Rogowski Coil, aperture=Ø200mm

- PMC-RC-5000A-40mA-1P-300-PY-W-P**
1-phase 5000A/40mA Rogowski Coil, aperture=Ø300mm

Note: The Red, Yellow and Blue wire of 3-phase Rogowski coil correspond to A/B/C phase respectively.



Accuracy

Parameters	Accuracy			Resolution
	5A/1A Input		SCCT/ RC Input	
	Class 0.2S	Class 0.5S		
Voltage	±0.1%	±0.2%	±0.5%	0.001V
Current	±0.1%	±0.2%	±0.5%	0.001A
I4 Input	±0.1%	±0.2%	±0.5%	0.001A
P, Q, S	±0.2%	±0.5%	±1%	0.001kX
kWh, kVAh	IEC 62053-22 Class 0.2S/ IEC 62053-22 Class 0.5S ANSI C12.1 Class 0.2		IEC 62053-21 Class 1	0.1kXh
kvarh	IEC 62053-24 Class 0.5S IEC 62053-23 Class 2		IEC 62053-24 Class 1 IEC 62053-23 Class 2	0.1kvarh
PF	±0.2%	±0.5%	±1%	0.001
Frequency	±0.01Hz	±0.02Hz	±0.02Hz	0.01Hz
Ir Input	±0.5%			0.001A
THD	IEC 61000-4-7 Class II			0.001%
K-Factor	IEC 61000-4-7 Class II			0.001
Phase Angle	±1°			0.1°

Dimensions and Installation (Unit: mm)

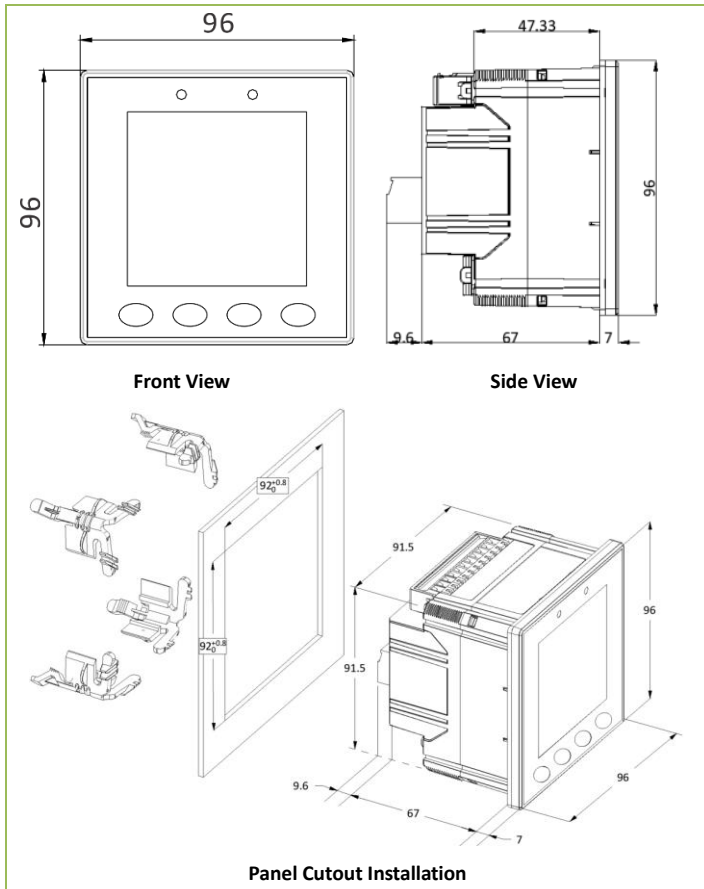

Terminals Diagram

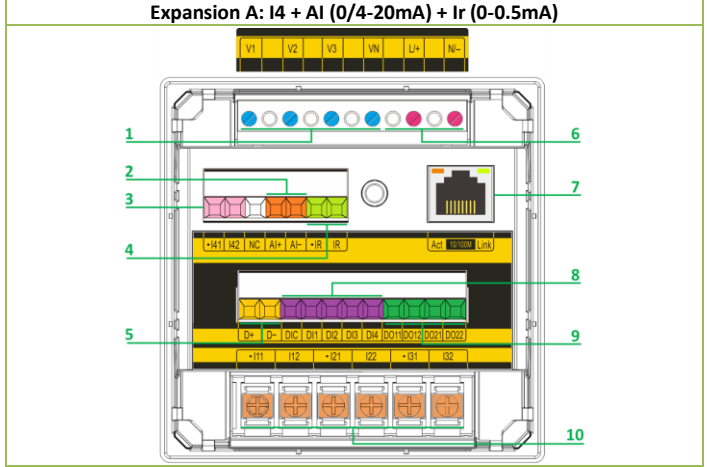

1	4x Voltage Input	6	Power Supply
2	Expansion A: Analog Input	7	10Base-T/100Base-TX Ethernet Port
3	Expansion A: I4 Input	8	4x Digital Input
4	Expansion A: IR Input	9	2x Digital Output
5	RS-485 Port	10	3x Current Input

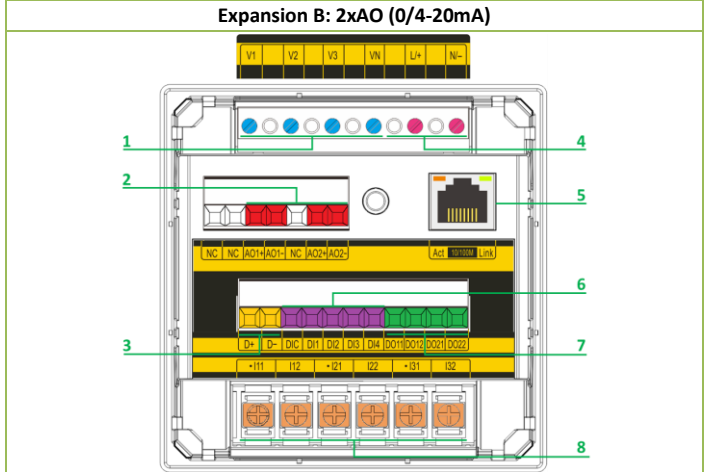

1	4x Voltage Input	5	10Base-T/100Base-TX Ethernet Port
2	Expansion B: 2x Analog Output	6	4x Digital Input
3	RS-485 Port	7	2x Digital Output
4	Power Supply	8	3x Current Input

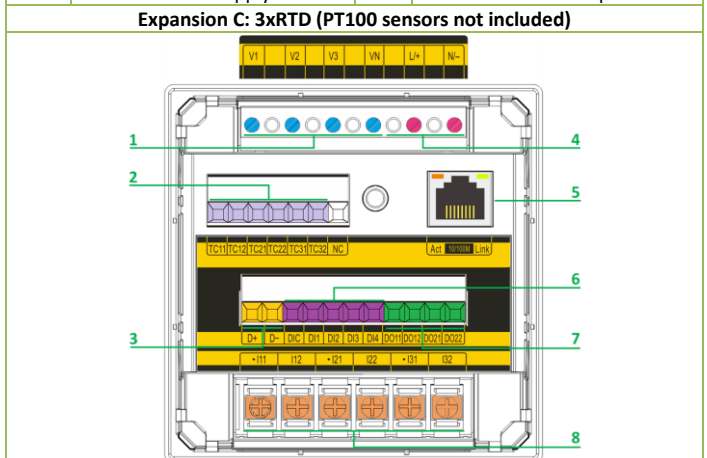

1	4x Voltage Input	5	10Base-T/100Base-TX Ethernet Port
2	Expansion C: 3x RTD	6	4x Digital Input
3	RS-485 Port	7	2x Digital Output
4	Power Supply	8	3x Current Input



Standards of Compliance

Ordering Information

Safety Requirements	
CE LVD 2014 / 35 / EU cULus Listed	EN 61010-1: 2010+A1: 2019 EN IEC 61010-2-030: 2021+A11: 2021 UL 61010-1, Ed.3, Rev 06/06/2023 CAN/CSA C22.2 NO. 61010-1, Ed.3 UL 61010-2-030, Ed.2 CSA C22.2 NO. 61010-2-030: 18, Ed.2
Electrical Safety in Low Voltage Distribution Systems up to 1000Vac and 1500 Vdc	IEC 61557-12: 2021 (PMD)
Insulation AC Voltage: 3.6kV @ 1 minute Insulation Resistance: >100MΩ Impulse Voltage: 6kV, 1.2/50μs	EN 61010-1: 2010+A1: 2019 IEC 62052-31: 2015
Electromagnetic Compatibility CE EMC Directive 2014 / 30 / EU (EN IEC 61326-1: 2021 + EN IEC 61326-2-3: 2021)	
Immunity Tests	
Electrostatic Discharge	EN 61000-4-2: 2009
Radiated Fields	EN IEC 61000-4-3: 2020
Fast Transients	EN 61000-4-4: 2012
Surges	EN 61000-4-5: 2014+A1: 2017
Conducted Disturbances	EN 61000-4-6: 2014+AC: 2015
Magnetic Fields	EN 61000-4-8: 2010
Voltage Dips and Interruptions	EN IEC 61000-4-11: 2020
Ring Waves	EN 61000-4-12: 2017
Immunity Standard for Industrial Environments	EN IEC 61000-6-2: 2019
Emission Tests	
Limits and Methods of Measurement of Electromagnetic Disturbance Characteristics of Industrial, Scientific and Medical (ISM) Radio-Frequency Equipment	EN 55011: 2016 + A1: 2017 + A11: 2020 + A2: 2021
Electromagnetic Compatibility of Multimedia Equipment - Emission Requirements	EN 55032: 2015+A11: 2020+A1: 2020
Limits for Harmonic Current Emissions for Equipment with Rated Current ≤16 A	EN IEC 61000-3-2: 2019+A1: 2021
Limitation of Voltage Fluctuations and Flicker in Low-Voltage Supply Systems for Equipment with Rated Current ≤16 A	EN 61000-3-3: 2013+A1: 2019+A2: 2021
Emission Standard for Industrial Environments	EN IEC 61000-6-4: 2019
Radiated Emissions	FCC 47CFR Part 15 Subpart B Class B ANSI C63.4: 2014
Conducted Emissions	FCC 47CFR Part 15 Subpart B Class B ANSI C63.4: 2014
Mechanical Tests	
Spring Hammer Test	IEC 62052-31: 2015
Vibration Test	IEC 62052-11: 2020
Shock Test	IEC 62052-11: 2020

Product Code		Description
PMC-53A-E Ethernet Multifunction Meter		
Basic Function		
E		Dot-Matrix LCD, Monthly & Daily Freeze Log, Data Recorder, 16MB Memory, 1x10Base-T/100Base-TX Ethernet Port and 1xRS-485 (Modbus RTU, BACnet MSTP and DNP 3.0)
Input Current		
5		5A (5A/1A Auto-Scaling)
1		1A
4		For use with 100A, 200A, 400A, 800A, 1600A to 40mA Split-Core CTs and 400A, 1200A, 2500A, 5000A to 40mA Rogowski Coils
Input Voltage		
9		400VLN/690VLL
Power Supply		
2		60-250VAC ± 10%, 47-440Hz 24-250VDC ± 10%
Frequency		
5		45Hz-65Hz
I/O		
A		4xDI + 2xDO (Mechanical Relay)
B		4xDI + 2xSS Pulse Output
Expansion		
X		None
A**A		14 + AI (0/4-20mA) + Ir (0-0.5mA)
B*		2xAO (0/4-20mA)
C*		3xRTD (PT100 sensors not included)
Language		
E		English
Accuracy[#]		
2*		Class 0,2S for Active Energy
" "		Class 0,5S for Active Energy
PMC-53A - E - 5 9 2 5 A X E 2		PMC-53A-E-5925AXE2 (Class 0,2S Standard Model)
PMC-53A - E - 5 9 2 5 A X E "		PMC-53A-E-5925AXE (Class 0,5S Standard Model)

* Additional charges apply
[^] I4 specifications of Analog Input Option A are consistent with those of the selected Input Current Option.
[#] The Accuracy Option represents for the accuracy of main unit. The Accuracy Option "2" is only available to Input Current Option "5" (for 5A Input) and "1". For Input Current option "4", the accuracy of main unit is Class 0,5S, excluding the accuracy of the externally connected SCTTs and Rogowski Coils.

CET Electric Technology Inc.

E: sales@cet-global.com

W: www.cet-global.com

Your Local Representative



Revision Date: March 18, 2026